

VISTAS

Observe com atenção as vistas das peças desenhadas à esquerda, e identifique as peças entre as perspectivas desenhadas à direita.

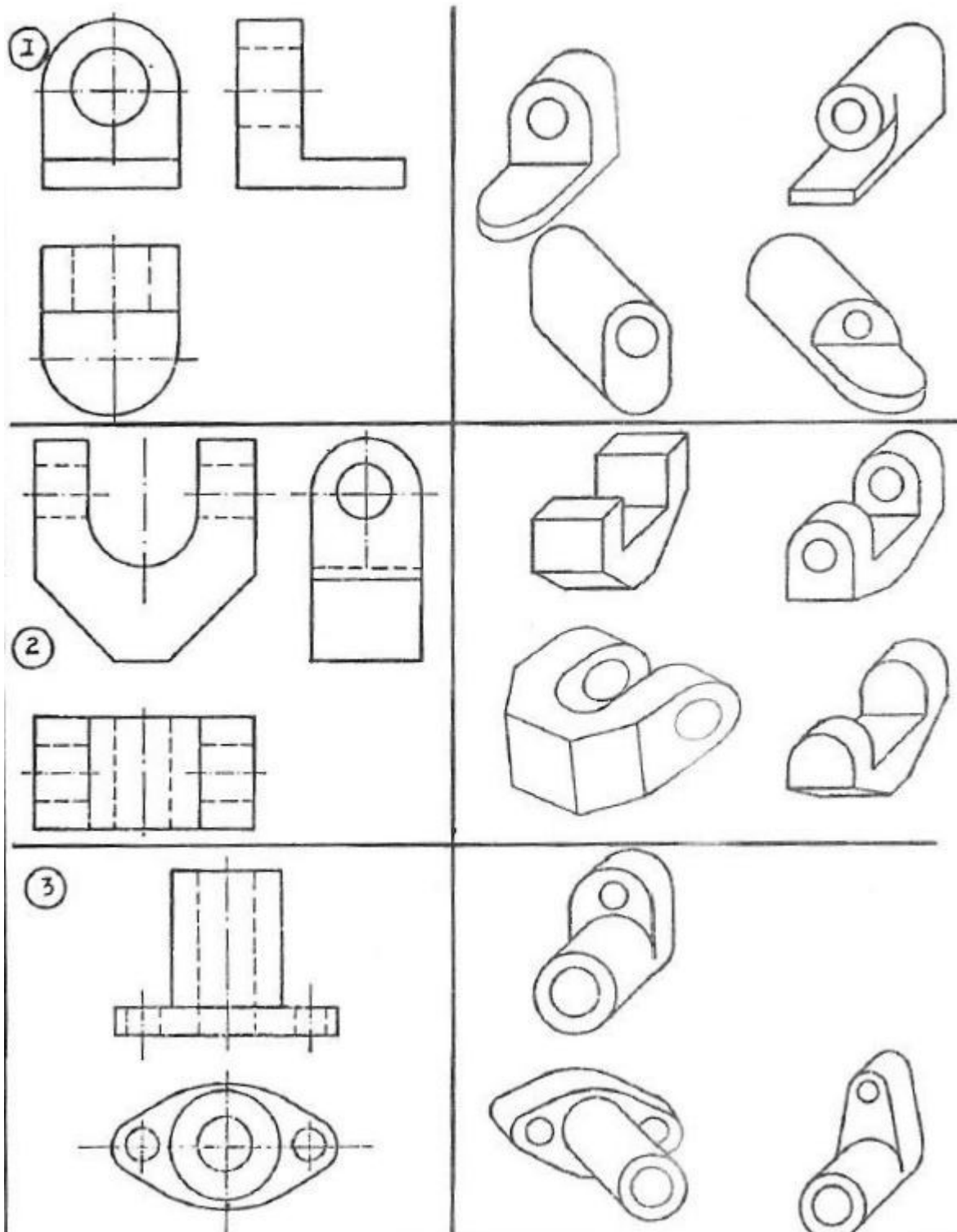
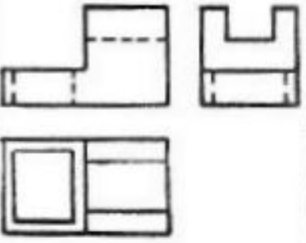
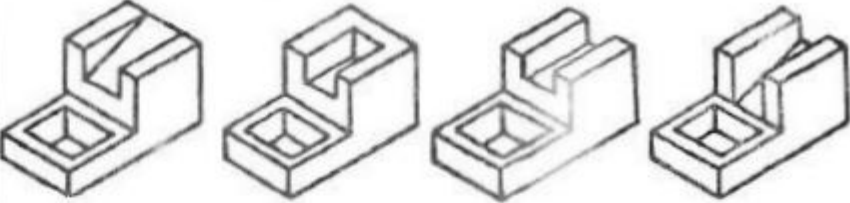
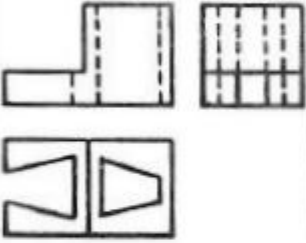
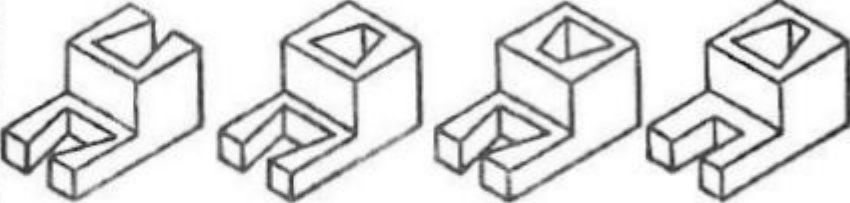
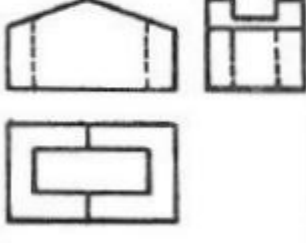
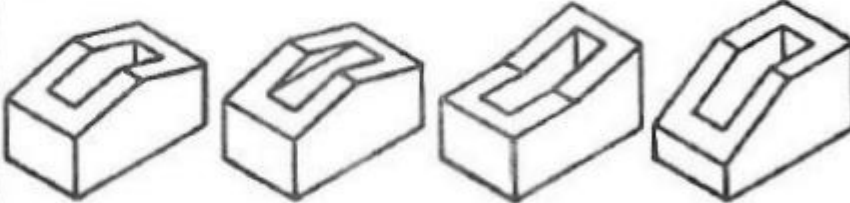
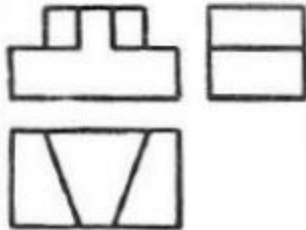
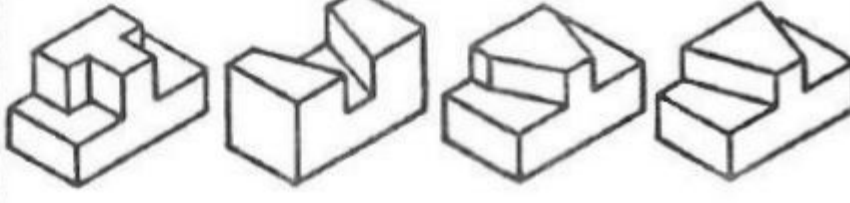

Assinale com um (X) qual das quatro peças colocadas à direita corresponde as vistas da coluna à esquerda.

VISTAS	PEÇAS EM PERSPECTIVA
	
	
	
	



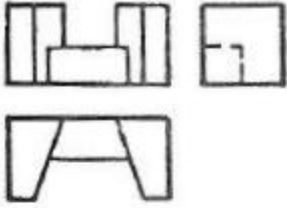
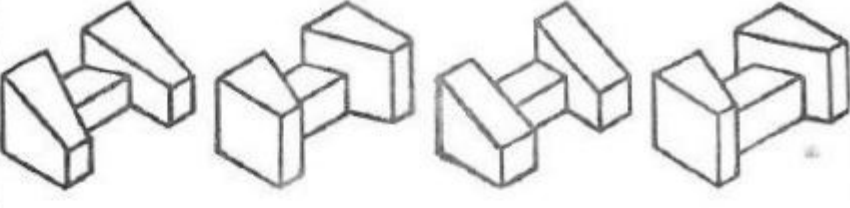
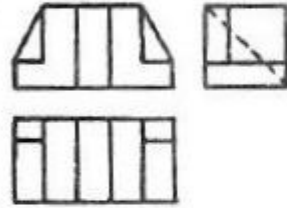
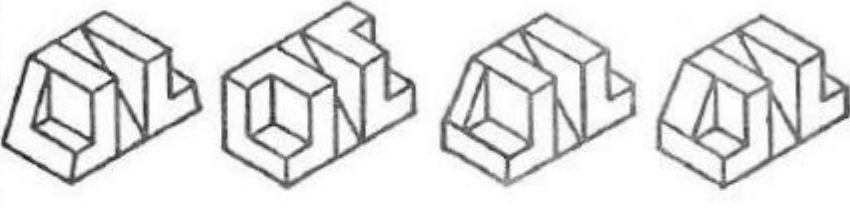
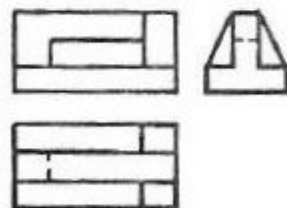
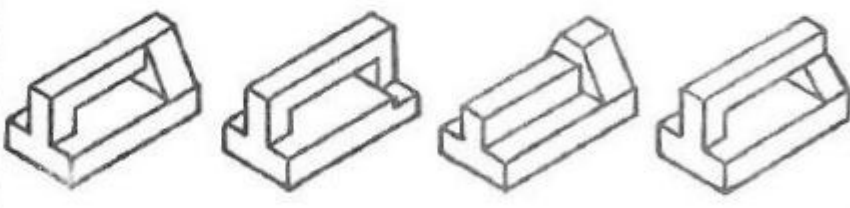
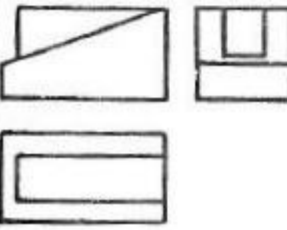
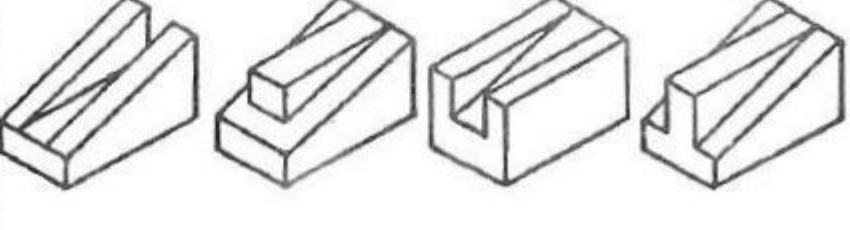



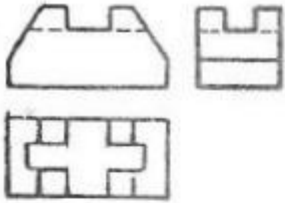
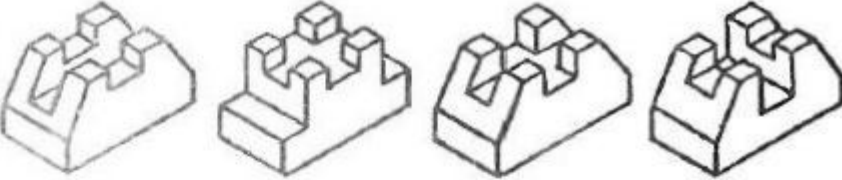
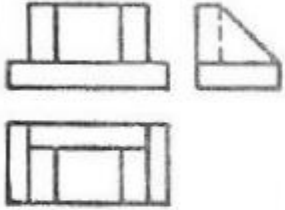
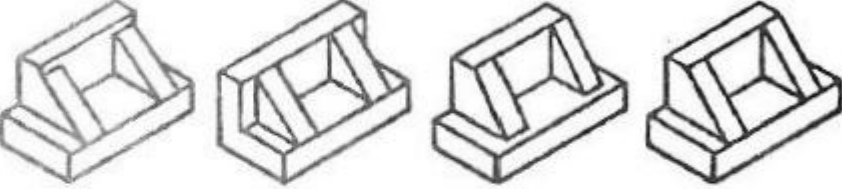
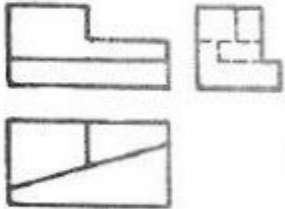
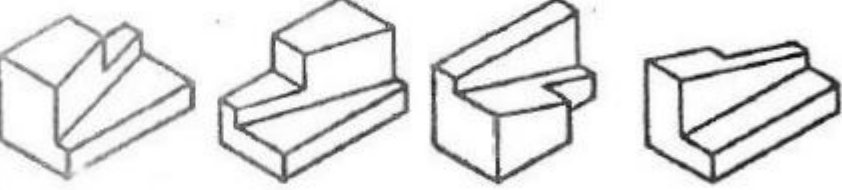
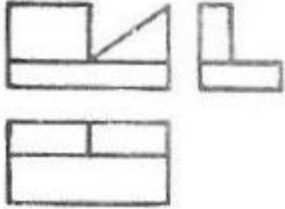
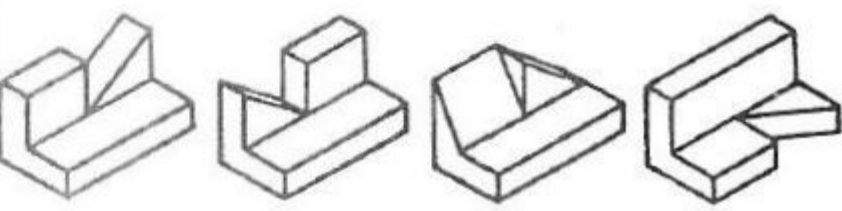



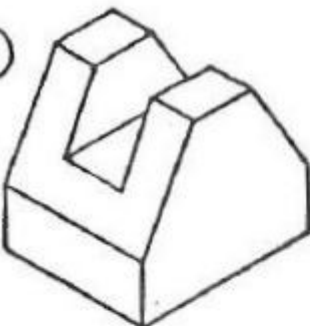

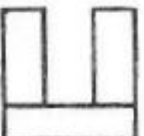
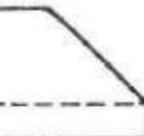
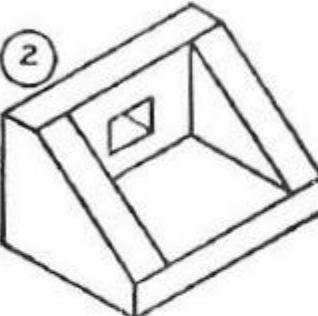

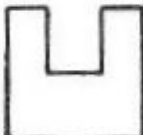
Assinale com um (X) qual das quatro peças colocadas à direita corresponde as vistas da coluna à esquerda.



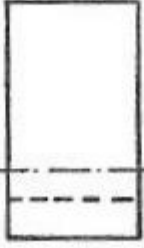
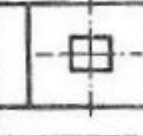

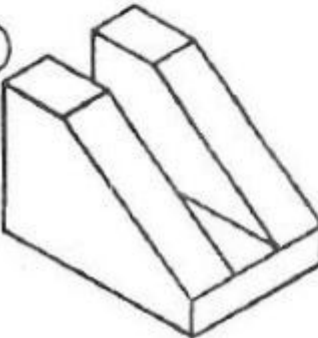
Assinale com um (X) qual das quatro peças colocadas à direita corresponde as vistas da coluna à esquerda.

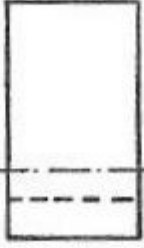
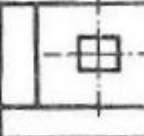
VISTAS	PEÇAS EM PERSPECTIVA
	
	
	
	

Identifique, entre as vistas desenhadas à direita a que corresponde a peça desenhada em perspectiva na coluna à esquerda.

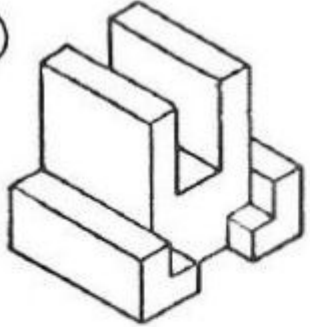
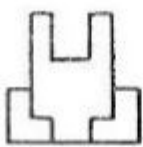
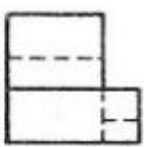
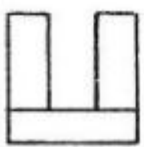
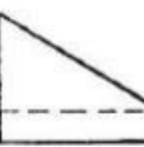
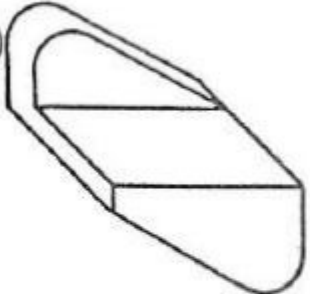
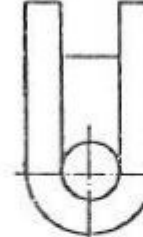
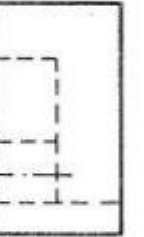
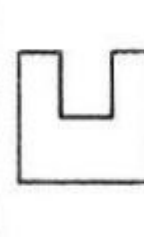
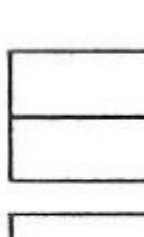
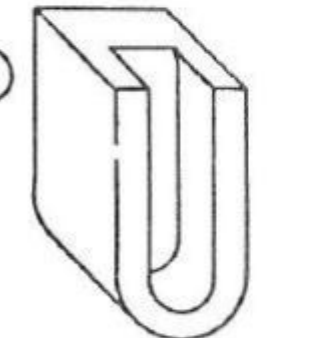
PERSPECTIVA	VISTAS			
<p>1</p> 				
<p>2</p> 				
<p>3</p> 				
<p>4</p> 				

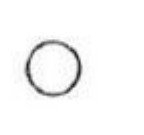
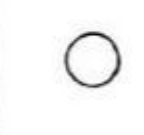
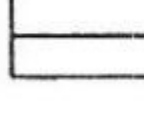
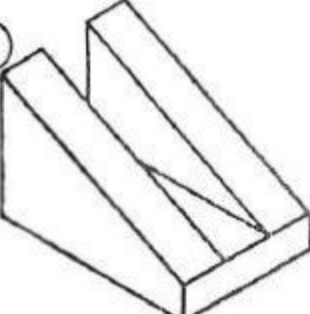
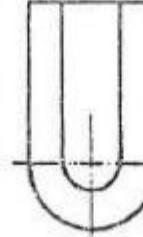
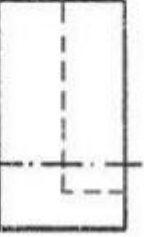
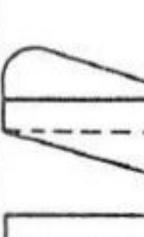
Identifique, entre as vistas desenhadas à direita a que corresponde a peça desenhada em perspectiva na coluna à esquerda.

PERSPECTIVA	VISTAS			
<p>①</p> 				
<p>②</p> 				
<p>③</p> 				
<p>④</p> 				

Observe que nas vistas desenhadas à esquerda existem elementos indicados com letras A, B, C e D procure identificá-los com as mesmas letras na perspectiva à direita.

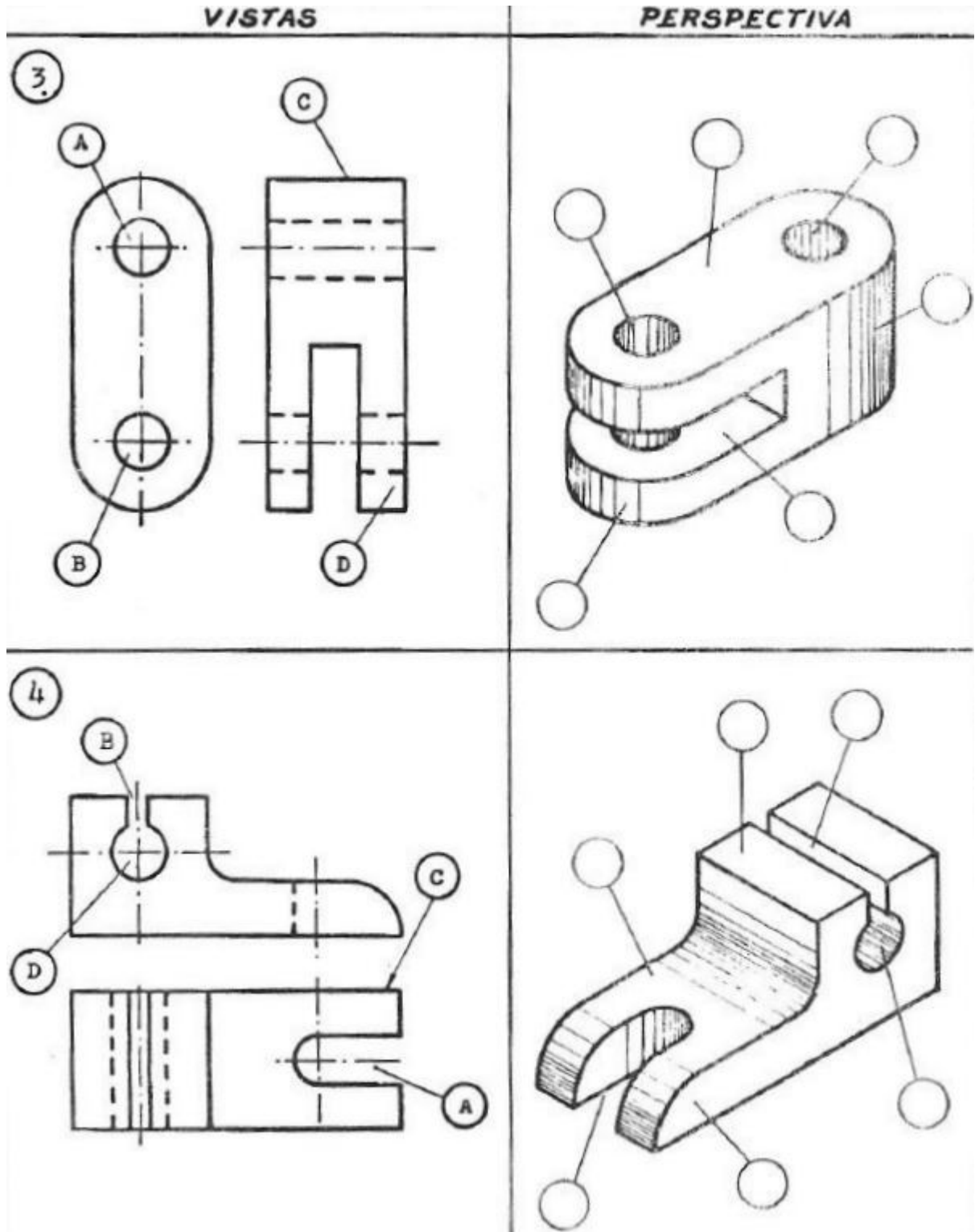

Observe que nas vistas desenhadas à esquerda existem elementos indicados com letras A, B, C, D e E. Procure identificá-los com as mesmas letras na perspectiva à direita.

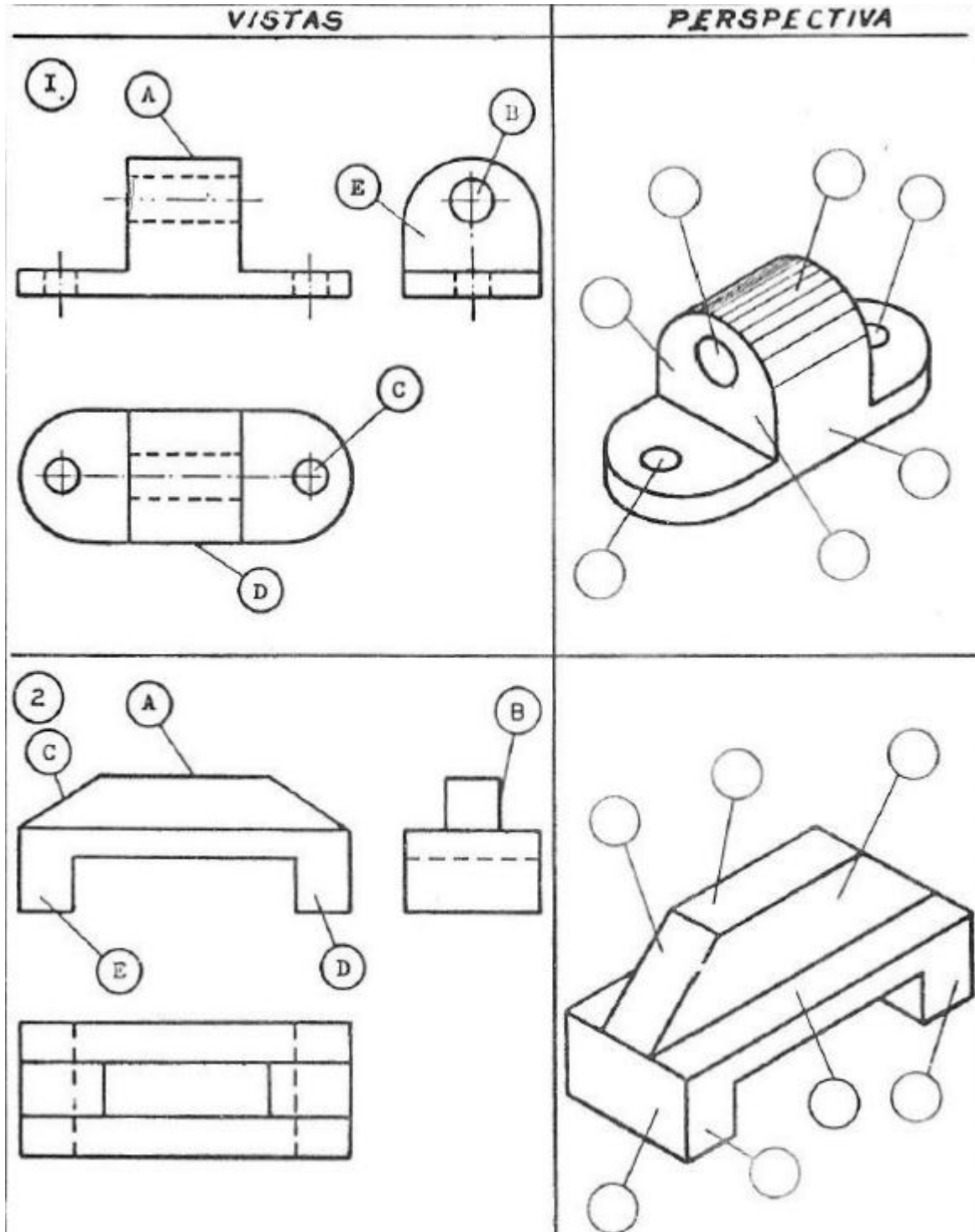

Observe que nas vistas desenhadas à esquerda existem elementos indicados com letras A, B, C, D e E. Procure identificá-los com as mesmas letras na perspectiva à direita.

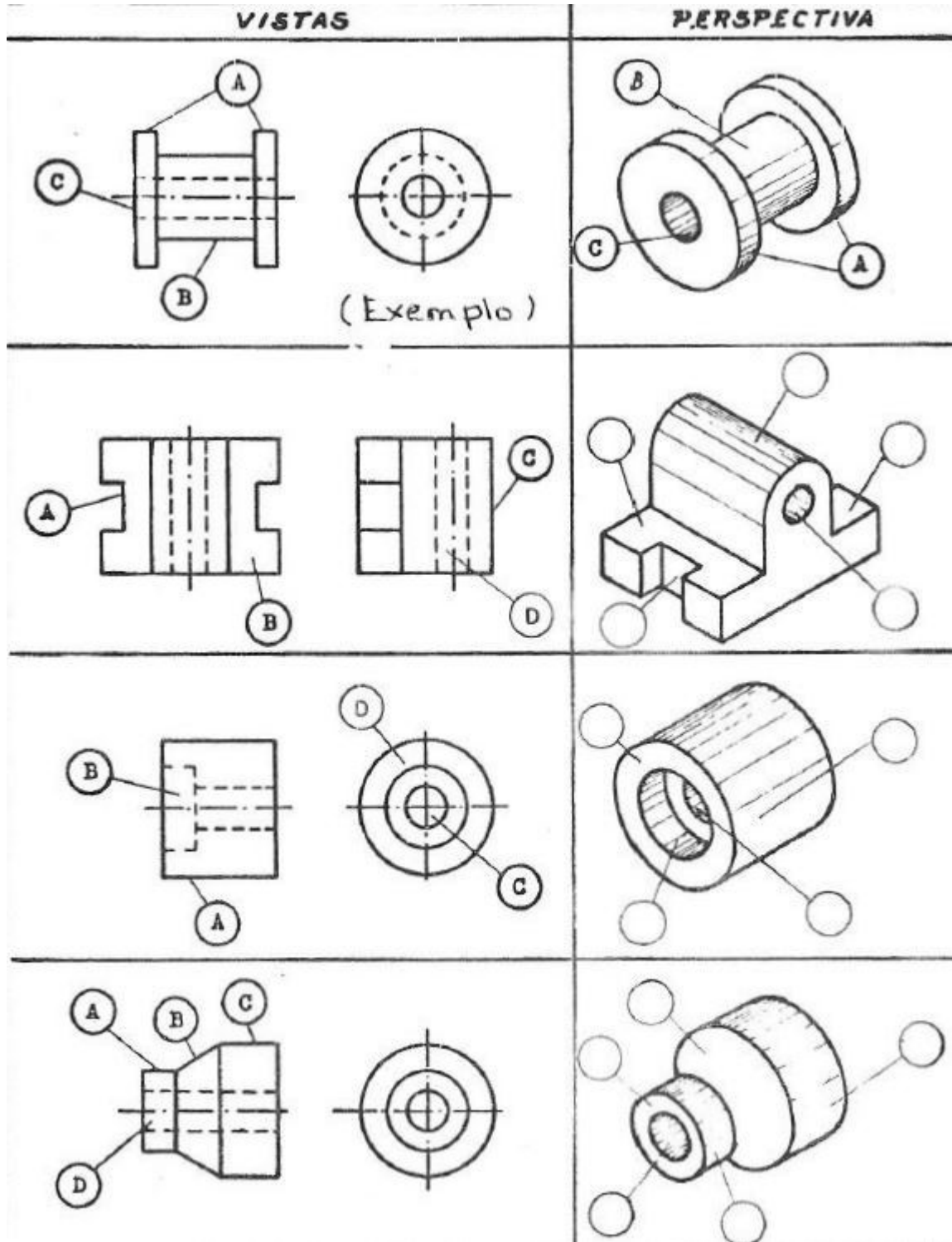



Numere na folha seguinte de acordo com as projeções abaixo, qual a peça em perspectiva. Identifique em cada peça os elementos indicados nas vistas com as letras A, B e C.

VISTAS	VISTAS
<p>1</p>	<p>2</p>
<p>3</p>	<p>4</p>
<p>5</p>	<p>6</p>
<p>7</p>	<p>8</p>

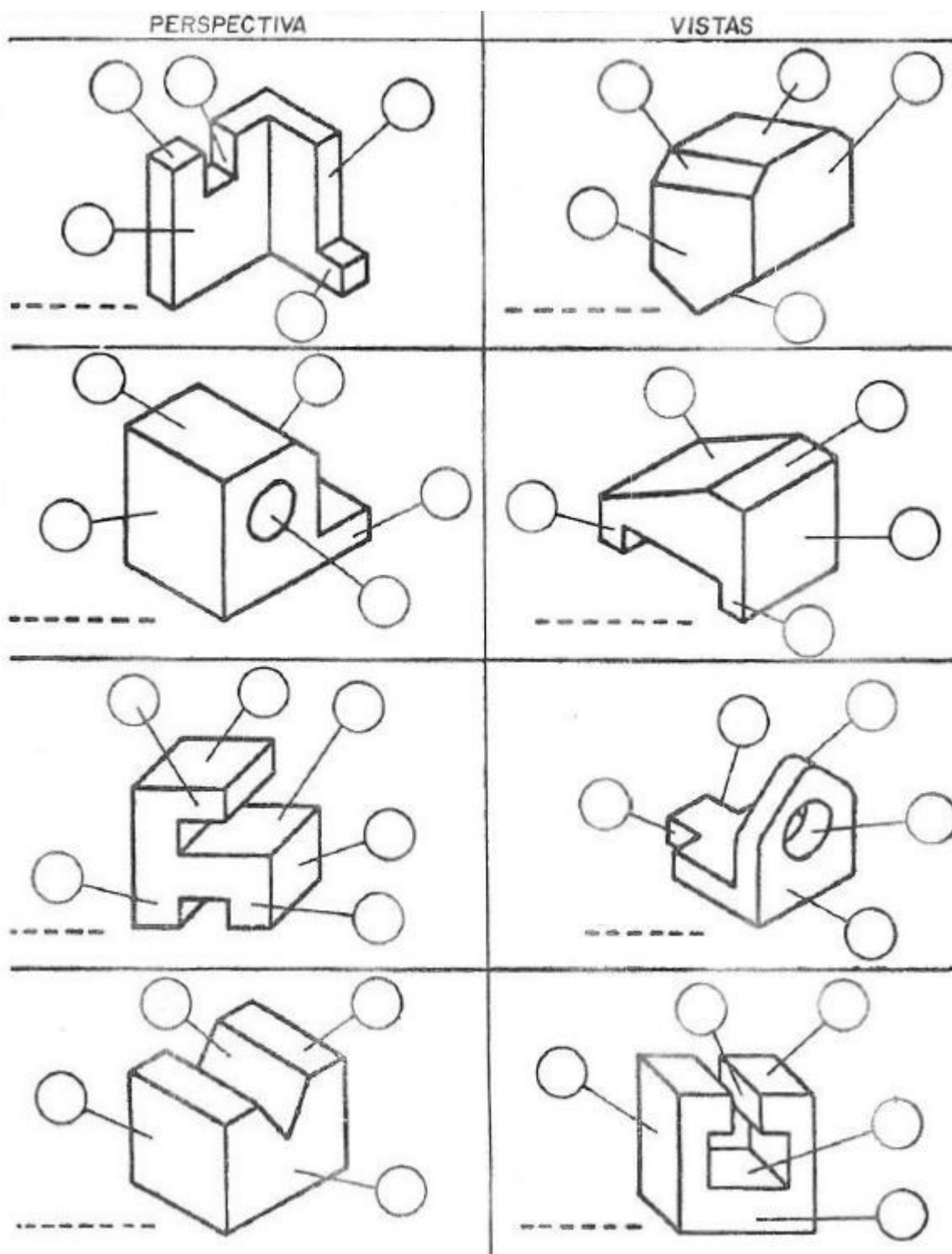
Peças em perspectiva, relativas à folha anterior.

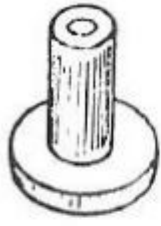
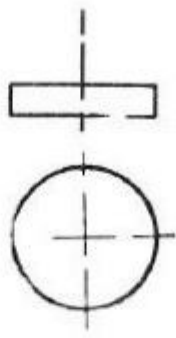
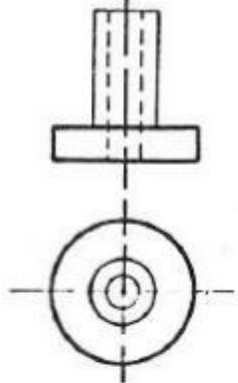
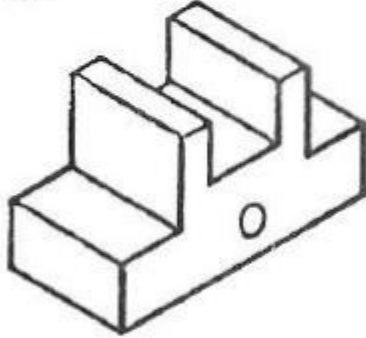
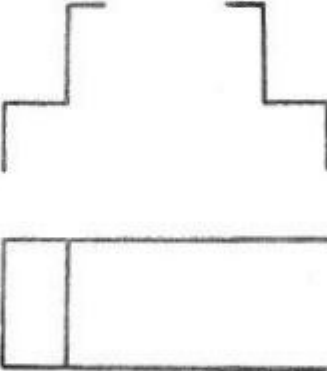
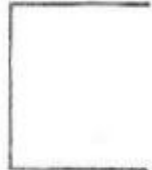
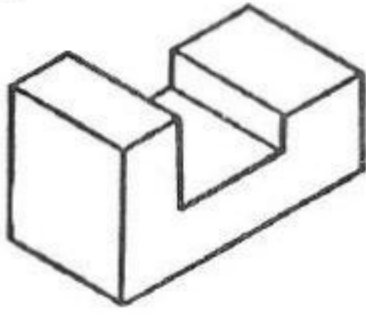
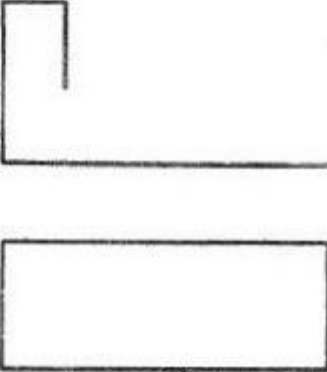

Desenhe, a mão livre, as linhas que estão faltando nas vistas de acordo com a peça em perspectiva. Observe o exemplo número 1.

PERSPECTIVA	VISTAS	
<p data-bbox="268 443 327 504">I</p> <p data-bbox="375 459 470 492">EXEMPLO</p> 	 <p data-bbox="758 828 1013 862">Desenho Incompleto</p>	 <p data-bbox="1125 828 1348 862">Desenho Completo</p>
<p data-bbox="279 929 343 996">2</p> 		
<p data-bbox="263 1422 327 1489">3</p> 		

Desenhe as linhas que estão faltando a mão livre nas vistas de acordo com a peça em perspectiva.

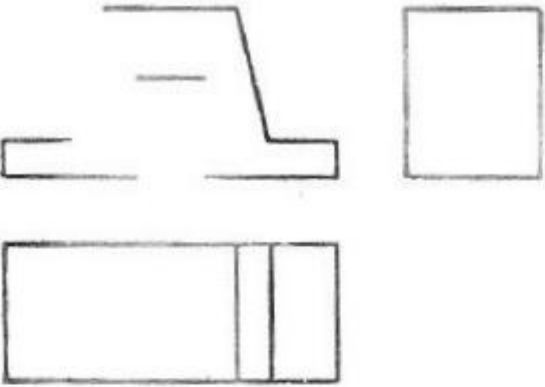
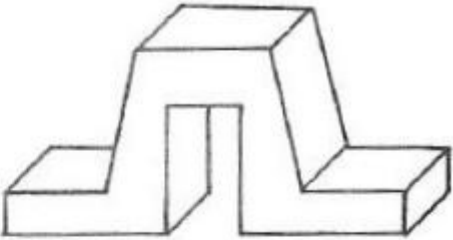
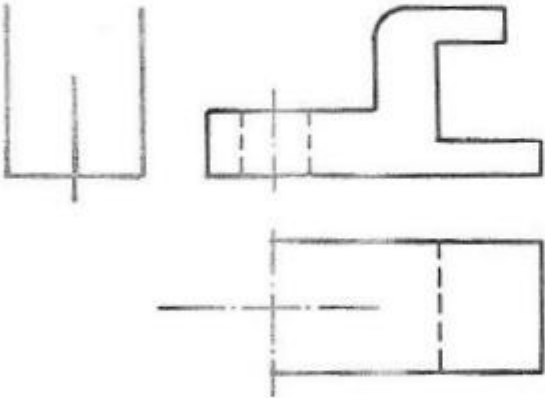
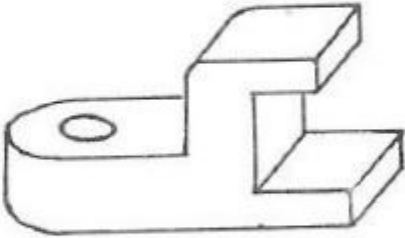
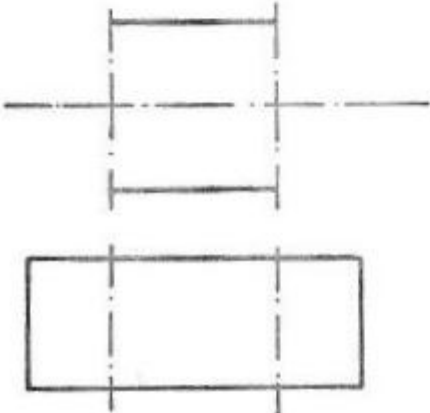
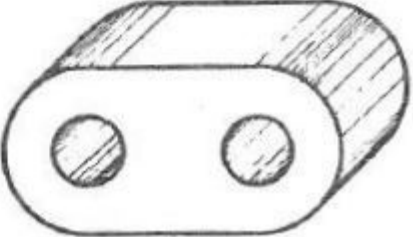
VISTAS	PERSPECTIVA
	
	
	

Desenhe as vistas que estão faltando a mão livre de acordo com a peça em perspectiva.

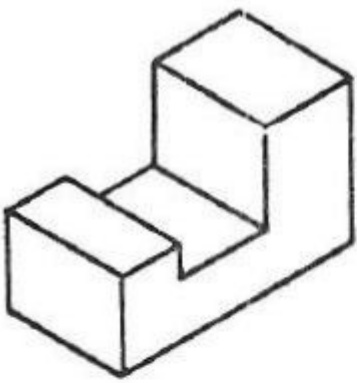
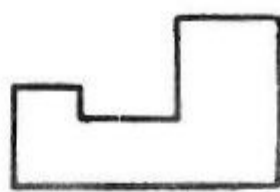
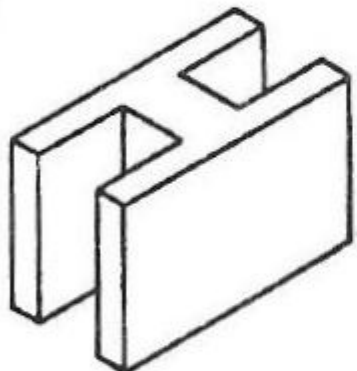
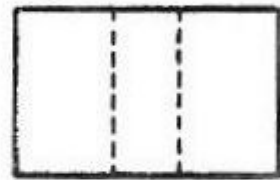
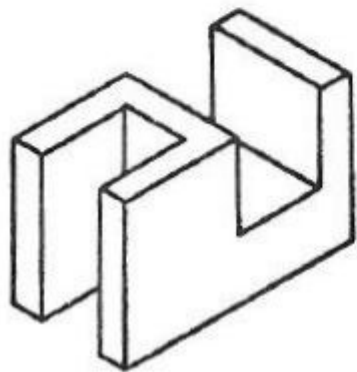
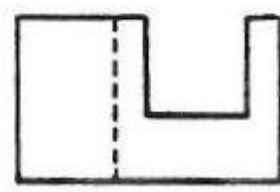
PERSPECTIVA	VISTAS
<p>1.</p> 	
<p>2.</p> 	
<p>3.</p> 	

Desenhe, a mão livre, aproveitando o quadriculado, as vistas que estão faltando, da peça situada na coluna à esquerda.

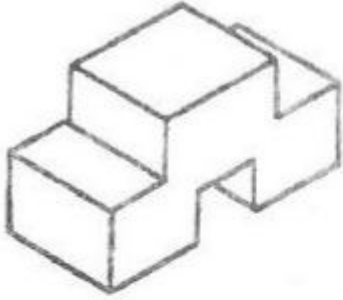
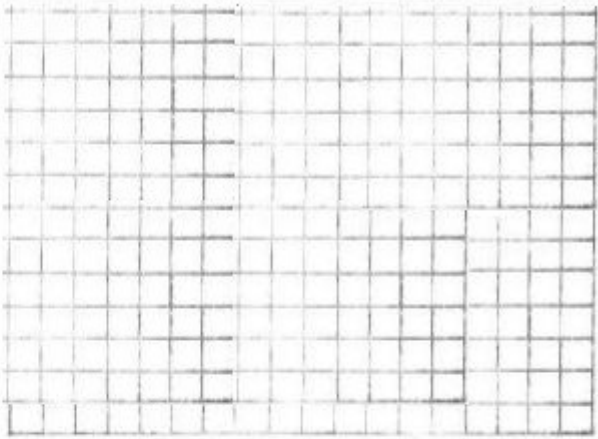
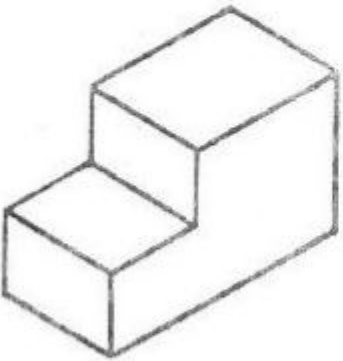
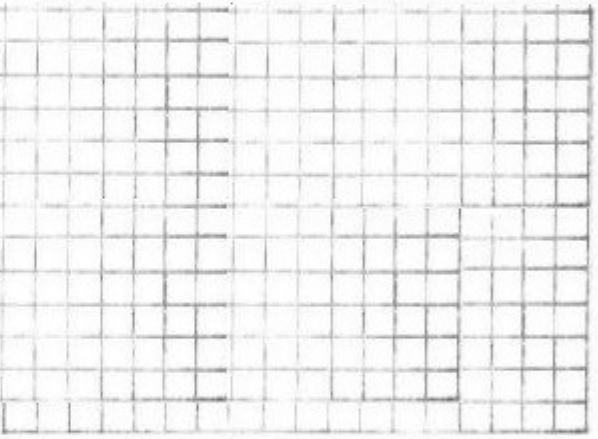
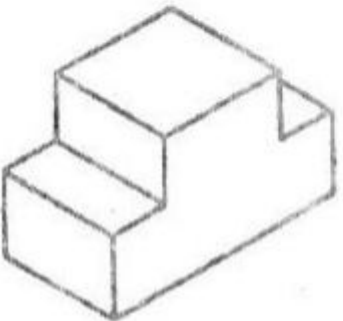
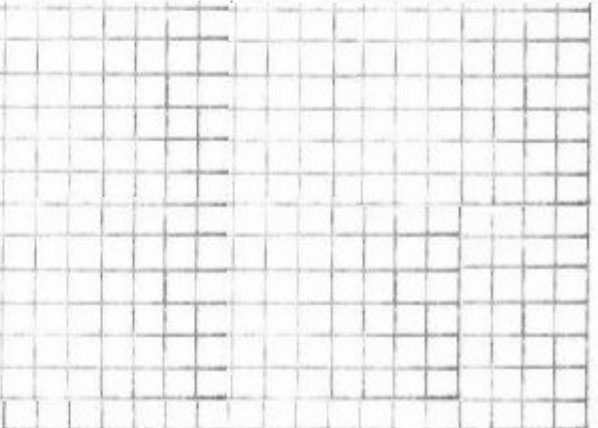
PERSPECTIVA	VISTAS
<p>①</p> 	
<p>②</p> 	
<p>③</p> 	

Desenhe, a mão livre, aproveitando o quadriculado, as vistas que estão faltando, da peça situada na coluna à esquerda.

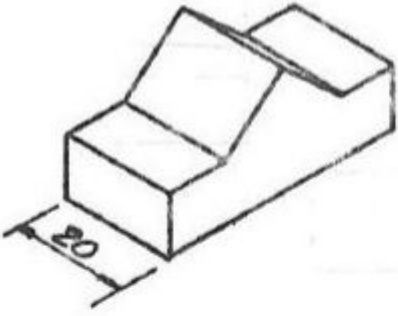
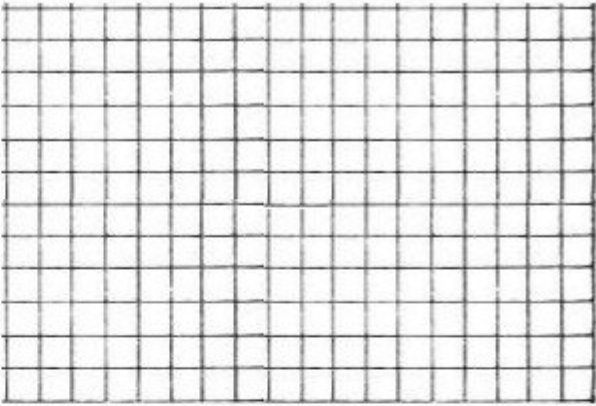
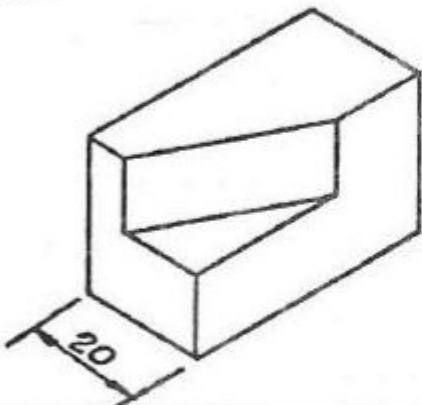
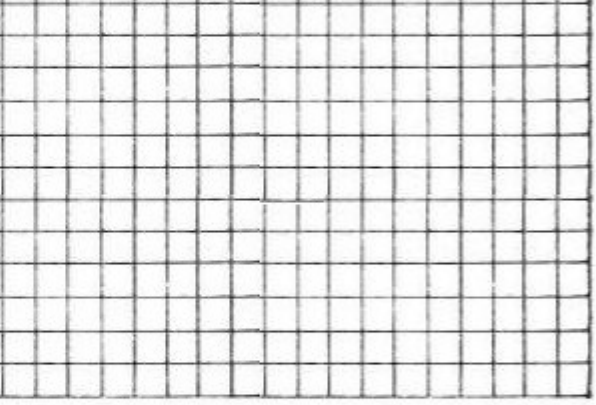
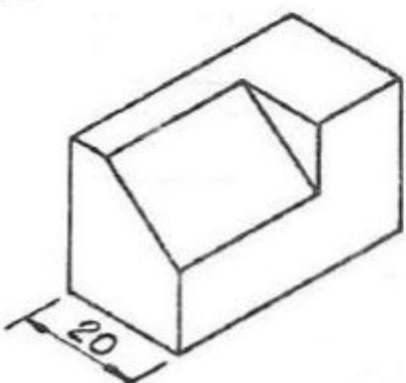
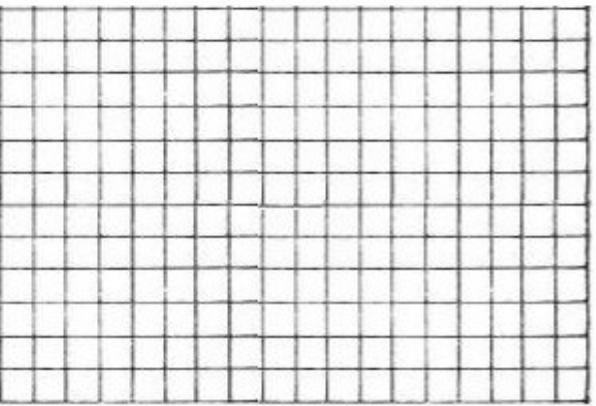
PERSPECTIVA	VISTAS
<p>①</p> 	
<p>②</p> 	
<p>③</p> 	

Desenhe, a mão livre, aproveitando o quadriculado, as vistas que estão faltando, da peça situada na coluna à esquerda.

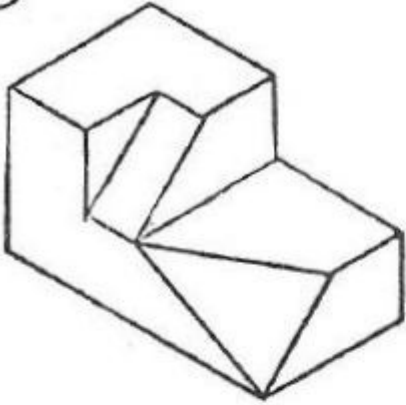
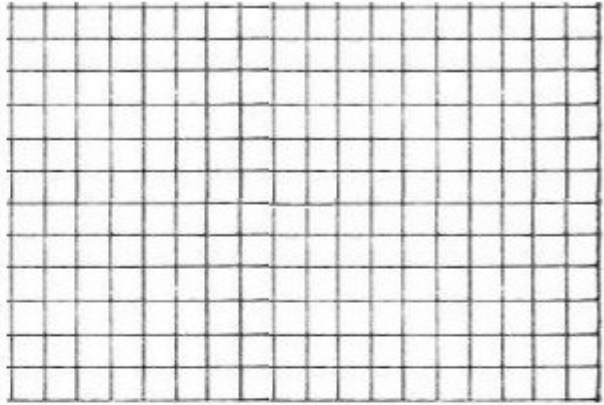
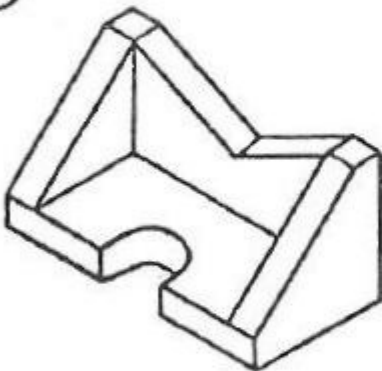
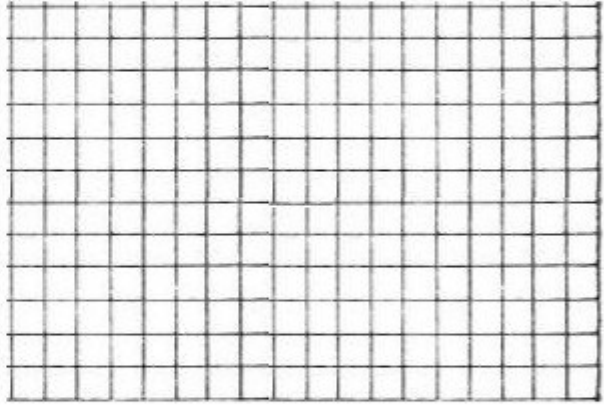
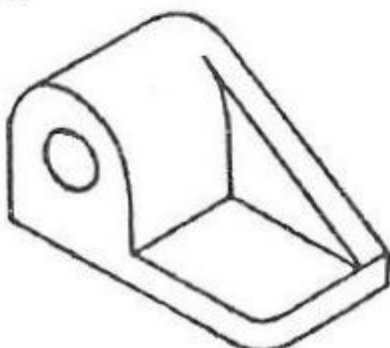
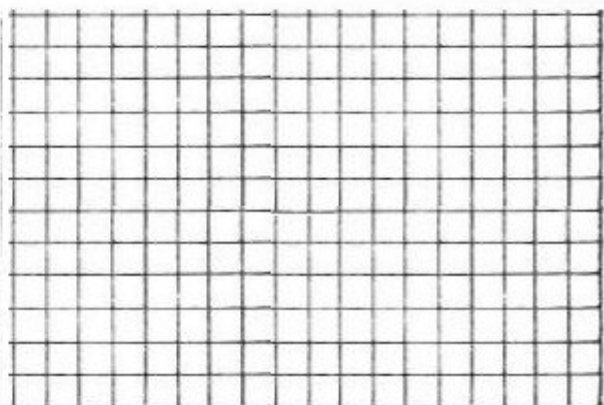
PERSPECTIVA	VISTAS
<p>①</p> 	
<p>②</p> 	
<p>③</p> 	

Desenhe, a mão livre, aproveitando o quadriculado, as vistas que estão faltando, da peça situada na coluna à esquerda.

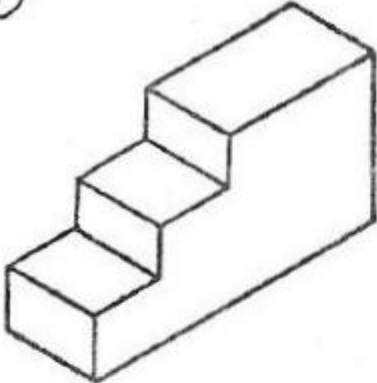
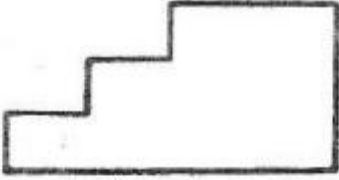
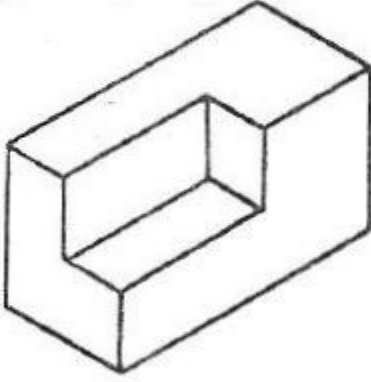
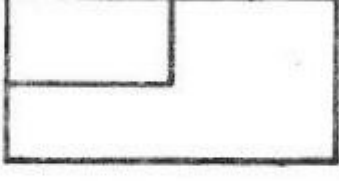
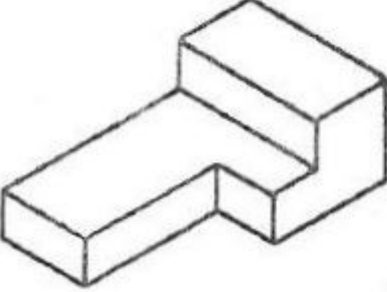
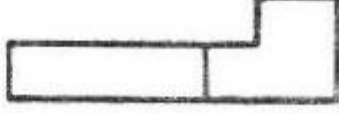
PERSPECTIVA	VISTAS
<p>①</p> 	
<p>②</p> 	
<p>③</p> 	

Identifique a peça desenhada em perspectiva à direita, pelas vistas desenhadas à esquerda. Trace, a mão livre, a vista que julgar faltante.

VISTAS		PERSPECTIVA	
1			
2			
3			

Identifique a peça desenhada em perspectiva à direita, pelas vistas desenhadas à esquerda. Trace, a mão livre, a vista faltante.

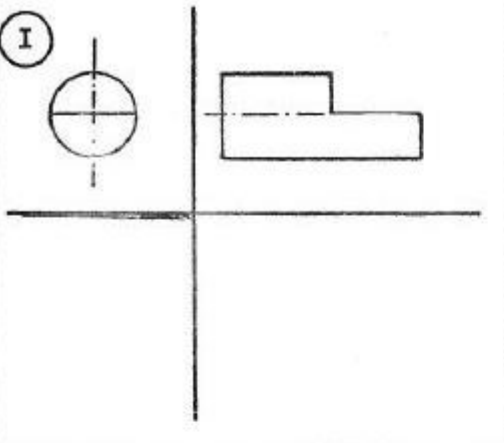
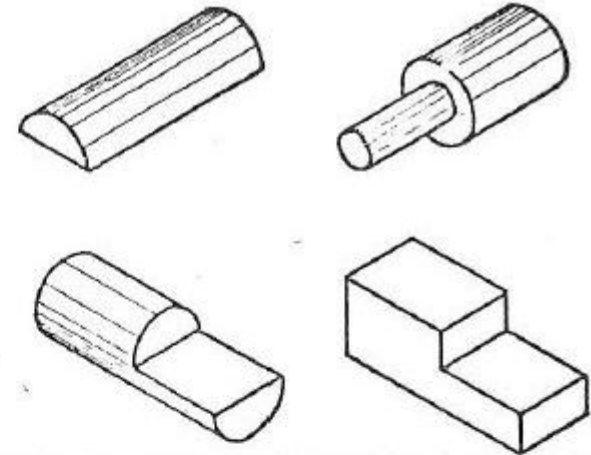
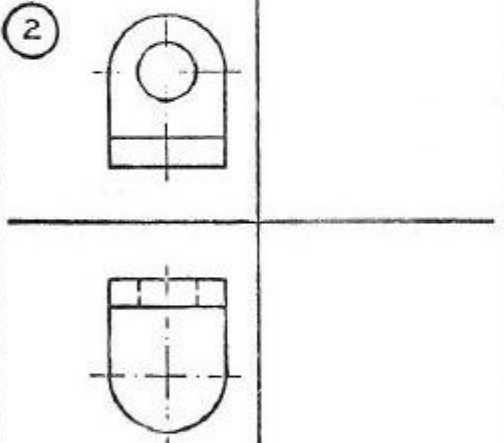
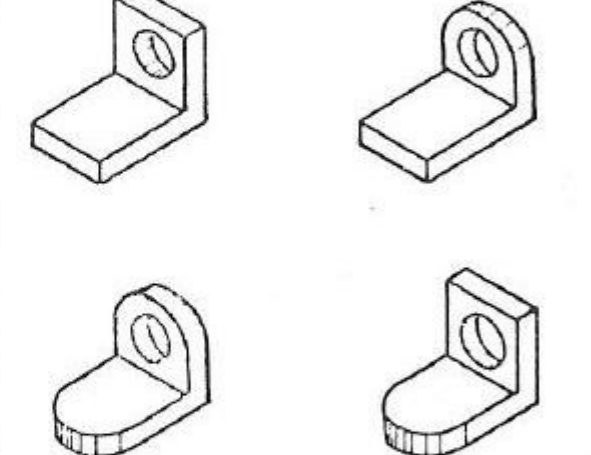
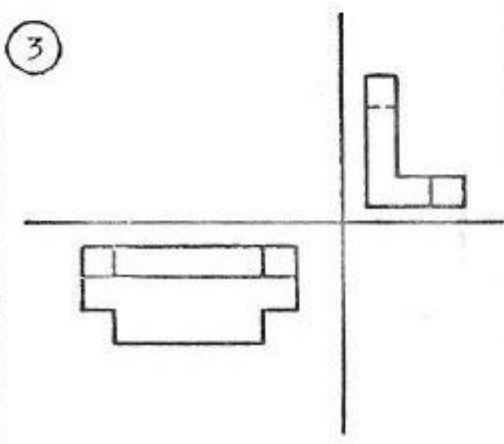
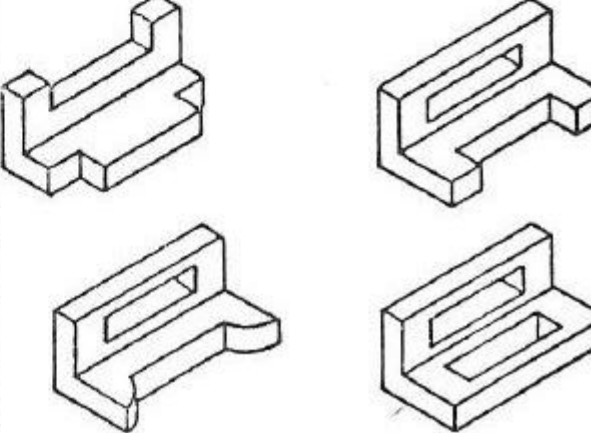
VISTAS	PERSPECTIVA
<p>1</p> 	
<p>2</p> 	
<p>3</p> 	

Desenhe as vistas que estão faltando nas projeções abaixo apresentadas.

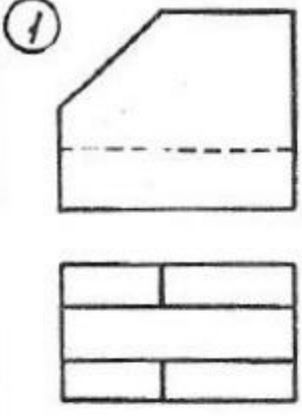
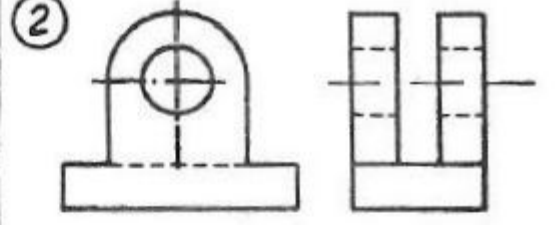
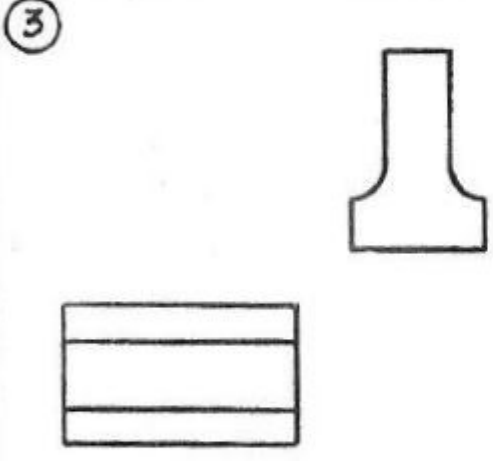
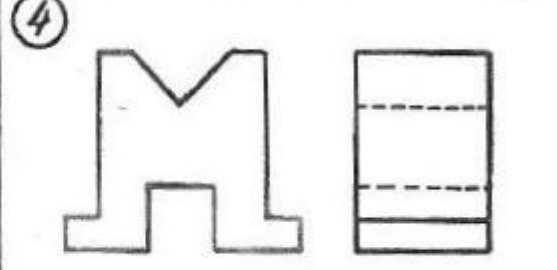
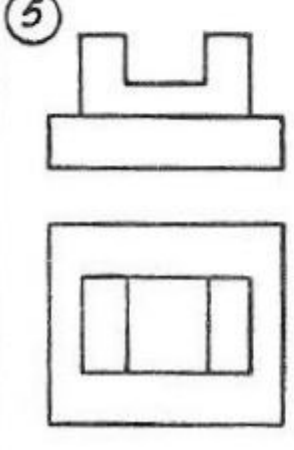
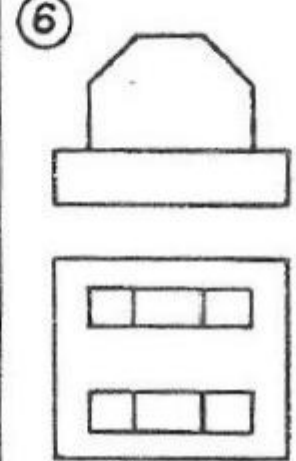
VISTAS	VISTAS
<p>①</p> 	<p>②</p> 
<p>③</p> 	<p>④</p> 
<p>⑤</p> 	<p>⑥</p> 

Desenhe as vistas que estão faltando nas projeções abaixo apresentadas.

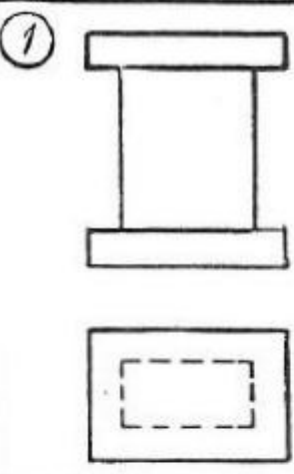
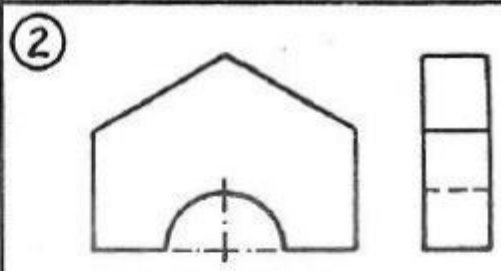
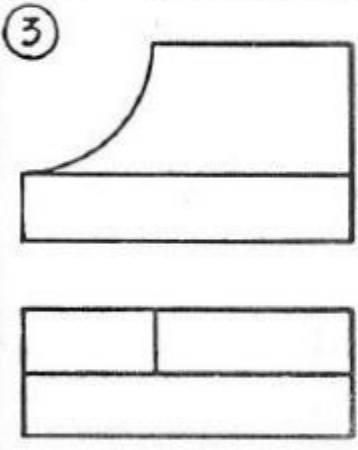
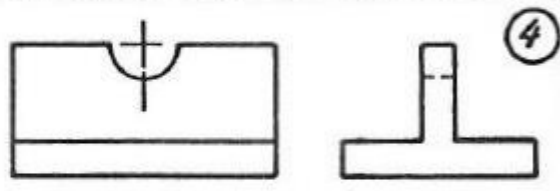
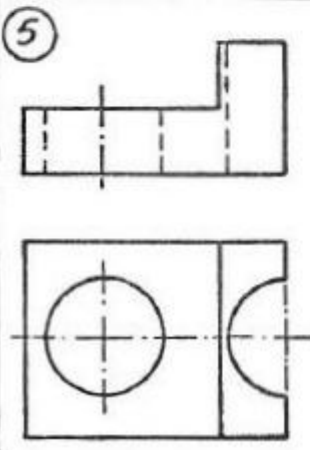
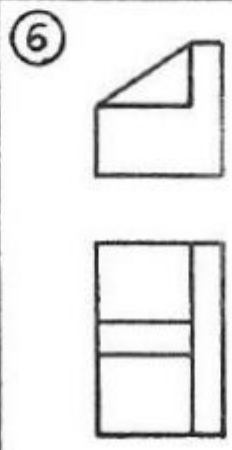
VISTAS		VISTAS	
<p>①</p> 		<p>②</p> 	
<p>③</p> 	<p>④</p> 		
<p>⑤</p> 		<p>⑥</p> 	

Desenhe as vistas que estão faltando nas projeções abaixo apresentadas.

VISTAS

①

②

③